

# MF SERIES INSTALLATION

## Installation

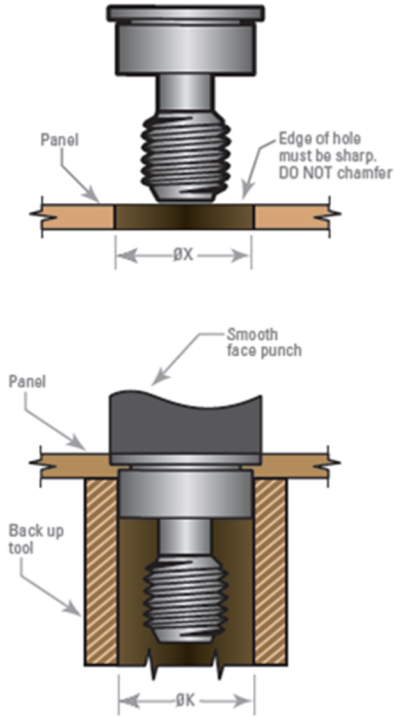

For installations in most aluminums or low carbon steels that are 1/4 hard or softer

THREAD SIZE	INSTALLATION DATA							
	Ø X +0.02/-0.00 (+.003/-.000)	M	F		P1		P2	Ø K +0.1/-0.05 (+.004/-.002)
			SLOTTED DRIVE	OTHER DRIVES	SLOTTED DRIVE	OTHER DRIVES		
<b>4-40 &amp; M3</b>	6.5 (.256)	1.3 (.050)	1.8 (.070)	2.4 (.095)	3.8 (.15)	3.8 (.15)	4.1 (.16)	6.6 (.260)
							5.1 (.20)	
							6.1 (.24)	
							7.1 (.28)	
<b>6-32</b>	7.5 (.295)	1.4 (.055)	2.2 (.085)	2.7 (.105)	3.8 (.15)	3.8 (.15)	4.3 (.17)	7.6 (.299)
							6.4 (.25)	
							7.4 (.29)	
<b>8-32 &amp; M4</b>	9.5 (.375)	1.5 (.060)	2.4 (.095)	3.2 (.125)	5.1 (.20)	4.3 (.17)	5.6 (.22)	9.6 (.379)
							6.6 (.26)	
							7.6 (.30)	
							8.6 (.34)	

Type	Thread Size	Panel Thickness		Panel Preparation			Part Number (See Callout to Select Items in Parenthesis)		
		Min	Max	X	Y	Z			
Press-in	4-40	0.9 (.036)	N/A	5.6 (.219)	N/A	3 (.120)	MMP-04 (Drive) 1- 1 - (Texture) (Finish/Mt'I)		
				6.4 (.250)		3.7 (.144)	MMP-04 (Drive) 3- 1 - (Texture) (Finish/Mt'I)		
	6-32			5.6 (.219)	N/A	3.2 (.126)	MMP-06 (Drive) 1- 1 - (Texture) (Finish/Mt'I)		
				8.0 (.315)		4.4 (.173)	MMP-06 (Drive) 3- 1 - (Texture) (Finish/Mt'I)		
	M3			5.6 (.219)	N/A	3.2 (.126)	MMP-M3 (Drive) 1- 1 - (Texture) (Finish/Mt'I)		
M4	8.0 (.315)	N/A	4.4 (.173)	MMP-M3 (Drive) 3- 1 - (Texture) (Finish/Mt'I)					
Flare-in	4-40	0.8 (.031)	2.4 (.094)	4.8 (.187)	0.4 (.016)	3 (.120)	MMF-04 (Drive) 1- 1 - (Texture) (Finish/Mt'I)		
				5.4 (.213)		0.8 (.032)	3.6 (.141)	MMF-04 (Drive) 1- 3 - (Texture) (Finish/Mt'I)	
	6-32			1.5 (.058)	3.2 (.125)	5.4 (.213)	0.4 (.016)	3.6 (.141)	MMF-06 (Drive) 1- 1 - (Texture) (Finish/Mt'I)
				3.2 (.126)	4.7 (.187)	1.6 (.063)		3 (.120)	MMF-06 (Drive) 1- 3 - (Texture) (Finish/Mt'I)
	M3			0.8 (.031)	2.4 (.094)	4.8 (.187)	0.4 (.016)	3 (.120)	MMF-M3 (Drive) 1- 1 - (Texture) (Finish/Mt'I)
				2.4 (.095)	4 (.156)	0.8 (.032)		3 (.120)	MMF-M3 (Drive) 1- 3 - (Texture) (Finish/Mt'I)
	M4			1.5 (.058)	3.21 (.125)	6.8 (.266)	0.4 (.016)	4.2 (.166)	MMF-M4 (Drive) 1- 1 - (Texture) (Finish/Mt'I)