

# MP SERIES (PRESS-IN) INSTALLATION

## PRESS-IN PANEL PREPARATION & INSTALLATION

1. Prepare installation hole for correct thread size\*. (Leave the hole edges sharp - DO NOT CHAMFER).
2. Press-in captive screw. Assure parallel surface on the punch and back-up tool.

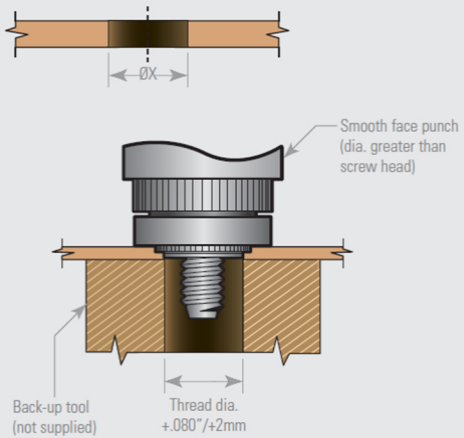

\*Recommended minimum distance from edge of panel to center line of hole is 1.5 x ØX for press-in

Thread	X (+.003/-0.000)
4-40	0.203
6-32	0.219
8-32	0.250
10-32	0.312
1/4-20	0.375

Thread	X (+.08/-0.000)
M3	5.50
M3.5	5.56
M4	6.40
M5	8.00
M6	9.50

# MP SERIES (FLARE-IN) INSTALLATION

## FLARE-IN PANEL PREPARATION & INSTALLATION

1. Prepare installation hole for correct thread size

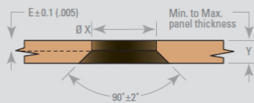

2. Install flare-in tool into press.
3. Center tool over screw thread. Use light pressure to flare the ferrule.

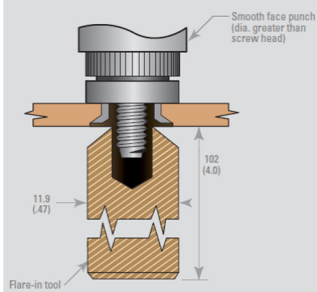

Thread	X (+.003/-0.000)
4-40	0.185
6-32	0.213
8-32	0.266
10-32	0.266
1/4-20	0.323

Thread	X (+.08/-0.000)
M3	4.7
M3.5	5.4
M4	6.8
M5	6.8
M6	8.2